



LRV 400

Light Reconnaissance Vehicle

SPECIFICATION SHEET



The Light Reconnaissance Vehicle 400 (LRV 400) has evolved considerably since its initial launch as a concept in 2012 and the exciting new 'Mk 2' LRV has become the latest addition to the Supacat range of high performance off-road military vehicles. For the 'Mk 2' LRV, Supacat have taken the rolling chassis and automotive systems from the Land Rover Discovery and adapted them for specialist military applications. Supacat are able to offer this vehicle as a fully integrated military variant including the entire spectrum of Integrated Logistic Support services.

'High speed through harsh environments' is the LRV's strength, offering the user an ideal lightweight rapid intervention vehicle for special forces, border patrol, reconnaissance or strike forces. The proven, rugged reliability of the Discovery base platform combined with Supacat's defence specific enhancements provides superb levels of performance, supportability and safety. The LRV's size and weight enables effective air portability, including tactical CH-47 internal loading. The LRV 400 can be converted from 4x4 to 6x6 to provide a flexible alternative configuration that increases payload and capacity.

A	Length	4635 mm
B	Width	1700 mm
C	Height	Min 1800 mm
D	Track	1585 mm
E	Wheelbase	2885 mm
F	Front Overhang	850 mm
G	Rear Overhang	900 mm
H	Ground Clearance	Min 180 mm (loading) Max 320 mm (standard)
I	Approach Angle	40°
J	Departure Angle	40°
K	Ramp Over Angle	153°

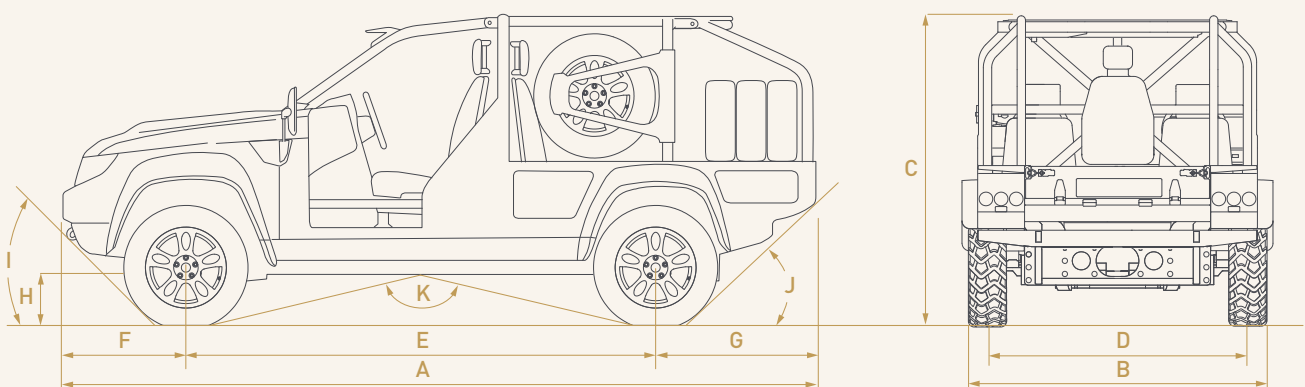

LRV 400 Vehicle Specification

Weight (GVW)	4200 kg
Payload (configuration dependent)	1700 kg
Kerb weight (configuration dependent)	2500 kg
Turning circle	(kerb to kerb) 11.5 m
Speed	160 km/h
Fuel capacity	80 Litres
Maximum road range	800 km
Power to weight	45 kW/tonne
Fording	750 mm
Gradient	60%
Side slope	40°
Engine	V6 3.0 Litre Diesel: Power 256hp Torque 600Nm
Transmission	8 speed automatic transmission Hi and Low range permanent 4WD with centre diff. lock
Differentials	Options including : Front and rear air locking
Suspension and axles	Front and rear fully independent double wishbone
Steering	Power assisted rack and pinion
Brakes	Ventilated disc all round
Tyres	245/70R17 as standard (other options available)
Electrical system	12v/24v DC



Options

Hutchinson bead-lock run flats, self-recovery winch, remote weapons station, weapon mounts, smoke grenade launchers, IR lights, ballistic armour and ballistic crew seats, RHD or LHD, on board water boiler, Pinnacle compass, canvas roof and side screens, forward and rear facing IR cameras, detachable polycarbonate windscreen, 12V and 24V electrics, NATO tow hook.

The LRV 400 can be converted from 4x4 to 6x6 to provide a flexible alternative configuration that increases payload and capacity.

