



# LRV 400

Light Reconnaissance Vehicle

SPECIFICATION SHEET



The Light Reconnaissance Vehicle 400 (LRV 400) has evolved considerably since its initial launch as a concept in 2012 and the exciting new 'Mk 2' LRV has become the latest addition to the Supacat range of high performance off-road military vehicles. For the 'Mk 2' LRV, Supacat have taken the rolling chassis and automotive systems from the Land Rover Discovery and adapted them for specialist military applications. Supacat are able to offer this vehicle as a fully integrated military variant including the entire spectrum of Integrated Logistic Support services.

'High speed through harsh environments' is the LRV's strength, offering the user an ideal lightweight rapid intervention vehicle for special forces, border patrol, reconnaissance or strike forces. The proven, rugged reliability of the Discovery base platform combined with Supacat's defence specific enhancements provides superb levels of performance, supportability and safety. The LRV's size and weight enables effective air portability, including tactical CH-47 internal loading. The LRV 400 can be converted from 4x4 to 6x6 to provide a flexible alternative configuration that increases payload and capacity.

A	Length	4635 mm
B	Width	1700 mm
C	Height	Min 1800 mm
D	Track	1585 mm
E	Wheelbase	2885 mm
F	Front Overhang	850 mm
G	Rear Overhang	900 mm
H	Ground Clearance	Min 180 mm (loading) Max 320 mm (standard)
I	Approach Angle	40°
J	Departure Angle	40°
K	Ramp Over Angle	153°

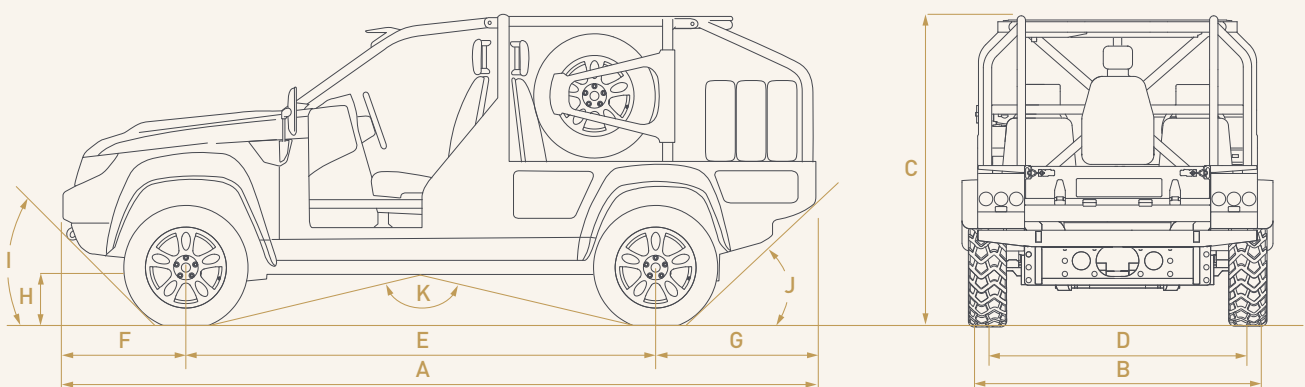

## LRV 400 Vehicle Specification

<b>Weight (GVW)</b>	4200 kg
<b>Payload (configuration dependent)</b>	1700 kg
<b>Kerb weight (configuration dependent)</b>	2500 kg
<b>Turning circle</b>	(kerb to kerb) 11.5 m
<b>Speed</b>	160 km/h
<b>Fuel capacity</b>	80 Litres
<b>Maximum road range</b>	800 km
<b>Power to weight</b>	45 kW/tonne
<b>Fording</b>	750 mm
<b>Gradient</b>	60°
<b>Side slope</b>	40°
<b>Engine</b>	V6 3.0 Litre Diesel: Power 256hp Torque 600Nm
<b>Transmission</b>	8 speed automatic transmission Hi and Low range permanent 4WD with centre diff. lock
<b>Differentials</b>	Options including : Front and rear air locking
<b>Suspension and axles</b>	Front and rear fully independent double wishbone
<b>Steering</b>	Power assisted rack and pinion
<b>Brakes</b>	Ventilated disc all round
<b>Tyres</b>	235/70 R17 as standard (other options available)
<b>Electrical system</b>	12v/24v DC



### Options

Hutchinson bead-lock run flats, self-recovery winch, remote weapons station, weapon mounts, smoke grenade launchers, IR lights, ballistic armour and ballistic crew seats, RHD or LHD, on board water boiler, Pinnacle compass, canvas roof and side screens, forward and rear facing IR cameras, detachable polycarbonate windscreen, 12V and 24V electrics, NATO tow hook.

The LRV 400 can be converted from 4x4 to 6x6 to provide a flexible alternative configuration that increases payload and capacity.

